



people's
trust for
endangered
species



**Hedgehog ecology
and land management**



Hedgehogs are declining

Hedgehogs are one of the few wild mammals we sometimes encounter up close and are a firm favourite of the British public. Sadly, we're seeing concerning population declines across the UK. Between 2000-14 hedgehog populations declined by over half in our countryside and nearly a third in our cities and suburbs.

Easy actions can have a big impact

But there's hope! Our recent analyses suggest the decline, at least in urban areas, may be slowing, possibly even turning around. The concerted efforts of communities could be working. Sympathetic green-space management and design by local authorities, businesses and private land managers whether it be schools, cemeteries or golf clubs, has the potential to really help bolster urban hedgehog populations. And, what's good for hedgehogs is good for many other species, including us.

This guide outlines several ways to better manage land to help hedgehogs:

- ▶ Reduce habitat loss and fragmentation by connecting up green spaces
- ▶ Remove hazards from the site
- ▶ Think about roads and controlling hedgehog access to busy or dangerous areas
- ▶ Consider limiting predator access to certain areas of the site where hedgehogs are most vulnerable
- ▶ Keep an eye out for disease or illness in local hedgehog populations

Ecology and behaviour of hedgehogs

There are three main habitat requirements to consider when managing green space for hedgehogs:

- ▶ A range of nesting opportunities
- ▶ High quality feeding areas
- ▶ Ensuring varied habitats are well-connected

Nesting

Hedgehogs nest year-round and produce different types of nest for day-time resting, breeding and hibernation. Day-time nests are a retreat during the active season, and are often temporary, flimsy and found in areas of rough grassland, loose leaf piles or garden vegetation.



Breeding nests are made by females and are used to raise young. They tend to be more robust, like hibernation nests. Winter nests can be used for several months to hibernate through periods of cold weather and low food availability.

The most sturdy nests rely on medium-sized deciduous leaves and a structure to hold the leaves in place. Bramble patches, log piles and open compost heaps are common locations for breeding nests and hibernacula.

Feeding

Hedgehogs are omnivores, but the bulk of their diet consists of macro-invertebrates such as beetles, worms, slugs, earwigs, caterpillars and millipedes. In urban areas, supplementary food in the form of cat, dog or formulated hedgehog food can make up a significant part of their diet. Access to water is also very important.

Habitat

Hedgehogs are highly active and range widely. They need to be able to move freely through a well-connected range of habitats to find food, mates and areas to nest. Radio-tracking studies show that hedgehogs can travel around 2km in a night in urban areas, and up to 3km a night in rural landscapes, though distances differ between the sexes. A viable population of urban hedgehogs is thought to need around 0.9km² of well-connected habitat.



The hedgehog's year

Hedgehogs are nocturnal animals, so despite their charismatic spiny appearance they are often difficult to find. They're solitary creatures, don't hold territories and rely mainly on their hearing and sense of smell. Hedgehogs are also generalists, meaning they have a varied diet and are widespread, but generally absent from moors, marshes and pine forest.

Timings of many hedgehog behaviours are dependent on temperature, gender and the body condition of the individual hedgehog. Actions at particular times of year will, however, help reduce hazards and help hedgehogs thrive.

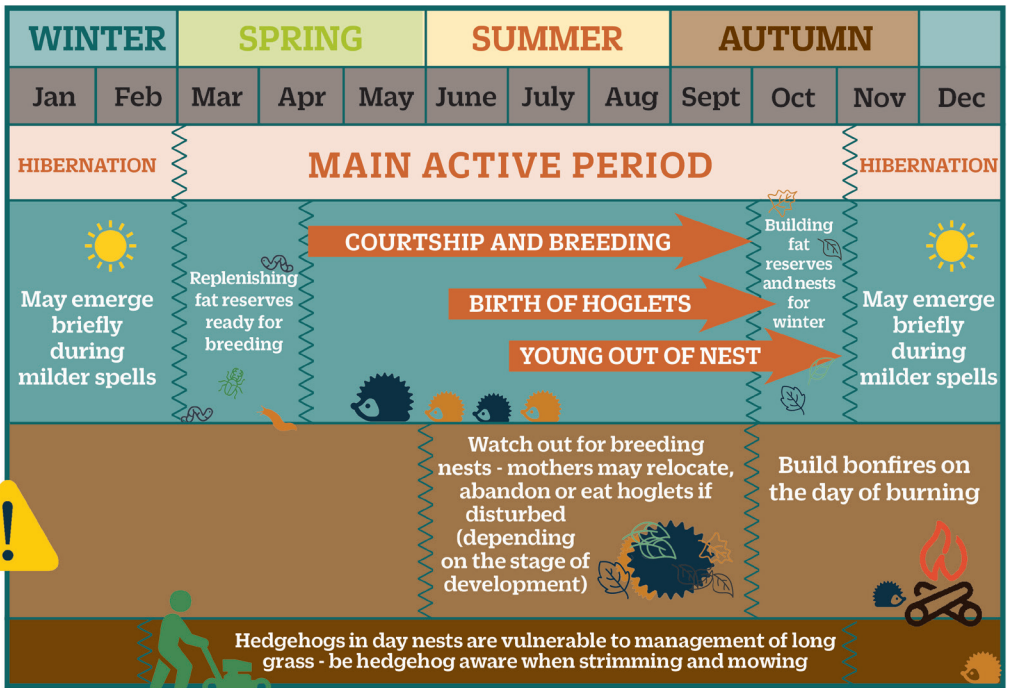

Why are hedgehogs declining?

Hedgehogs face a multitude of natural and anthropogenic threats, many of which act together and some of which are still being understood. Whilst habitat loss and fragmentation are major issues across both urban and rural habitats, the reasons differ between the two landscapes. But many of the threats are man made and can be reduced through simple changes in land management, providing an opportunity for green-space managers to make a real difference for local hedgehogs.

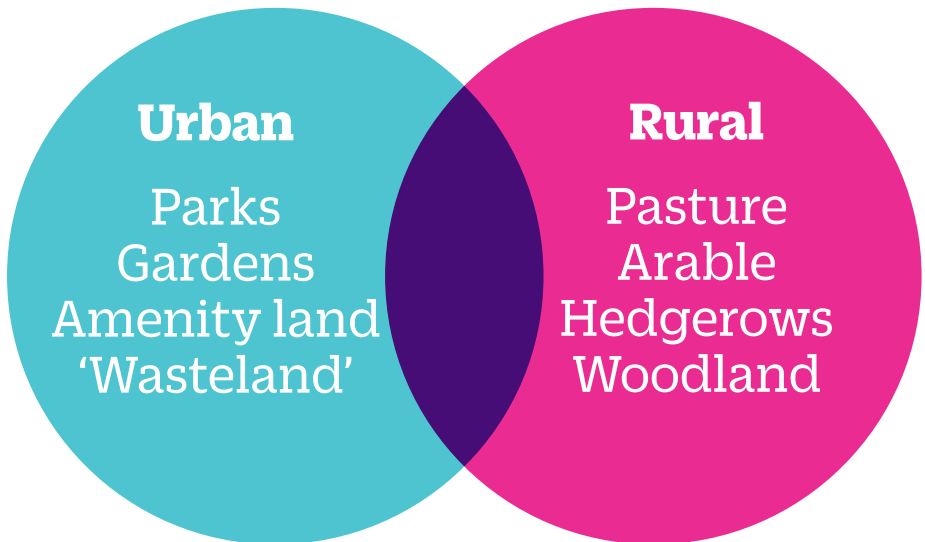

Impermeable boundaries

Tidy gardening
Slug pellets
Bonfire burning
Dangerous ponds
Strimming

Habitat fragmentation

Fewer invertebrates
Road traffic
Refuse e.g. plastic
Climate change

Land use change

Pesticides (indirect)
More badgers
Flailing or tilling
Gamekeepers

Roads

Roads can act as barriers to hedgehog movement, may have genetic impacts on populations and are a large source of mortality. It has been estimated that between 167,000 – 335,000 are killed on our roads in Great Britain every year.

The solution

Road signs could alert drivers in areas of high hedgehog density, and green-space fencing could help channel hedgehog movement away from major roads. Well-connected green spaces, linked with surrounding gardens, will also reduce the need for hedgehogs to cross roads.

Road mitigation such as overbridges, underpasses and culverts are likely beneficial, as long as they are maintained and not permanently water logged or water filled.



Habitat loss & fragmentation in the countryside

Evidence shows that hedgehogs are fairing particularly poorly across agricultural landscapes. This is due to a range of factors, including; habitat fragmentation from loss of hedgerows, larger field sizes, increased pesticide use and limited areas of scrub, decaying wood or nectar rich planting. All these factors increase hedgehogs vulnerability to predation. Many farmers across the UK already do fantastic work for wildlife, but if hedgehogs are to thrive in our countryside they need a sustained effort from us all.

The solution

- ▶ Hedgerow planting and management
- ▶ Field margin management
- ▶ Reduced field sizes
- ▶ Reduced ploughing and tilling rates
- ▶ Keeping areas of scrub and decaying wood

Countryside Stewardship schemes can also help hedgehogs and other desirable wildlife.

More detailed information can be found in our farmers advice guide that can be obtained for free by contacting hedgehogs@ptes.org or by downloading it electronically from our website www.hedgehogstreet.org/farmersadvice



Habitat loss & fragmentation in our cities and suburbs

Despite covering just 6% of land, urban landscapes are increasingly important for hedgehogs. The matrix of gardens and green spaces in towns and cities can support the highest densities of hedgehogs and may act as a refuge from agricultural practices and high predator density.

Habitat loss from new developments, in-filling of gardens with housing, roads, impermeable boundaries and 'over-management' of green-spaces and gardens are all, however, threats.

The solution

Hedgehog Highways

Link parcels of land by ensuring boundaries are permeable to hedgehogs. Hedging or hedgehog-sized holes in fencing or walls help create Hedgehog Highways. Ground-level boundary holes should measure 13x13cm and should link as many neighbouring pieces of land as possible. These are easy to include for most fencing contractors, and both wooden and concrete hedgehog-friendly gravel boards can be purchased from some suppliers ready-made. Cinder blocks or piping can be used to deter use by pets. Hedgehog

Highway plaques can be purchased from both People's Trust for Endangered Species (PTES) and British Hedgehog Preservation Society (BHPS) online stores to raise awareness and mark the purpose of these gaps to curious neighbours.



Wild areas for nesting and feeding

Areas of well-connected native hedging, scrub, bramble, shrubs, dead hedging and piles of dead wood become important nesting and foraging sites. Keeping fallen leaves on the ground or in accessible leaf stores is especially useful for breeding and winter nest building. Mosaic grass management provides the mix of long grass, short turf, open soil and tussocks needed for foraging and day nesting. Developing nectar sources and herbaceous vegetation provides the diverse microhabitats needed for the invertebrates hedgehogs rely upon. Edge habitat is especially important as hedgehogs often navigate landscapes by following linear features.



Hazards

Pesticides, herbicides and rodenticides

Pesticides, herbicides and rodenticides can be highly toxic, can impact non-target species, and can have both direct and indirect impacts on hedgehogs.

Herbicides can directly reduce earthworm density and reduce the varied ground cover needed for foraging. Slug pellets are potentially lethal if directly ingested and also reduce important prey sources.

The full impacts of many chemicals are still unknown but any product reducing the number of invertebrates also reduces the number of hedgehogs that can survive.

The solution

Avoid chemicals where possible and use organic alternatives where necessary. Wool pellets, nematode treatments, salt, seaweed, broken egg shells or coffee grounds are popular alternatives for slug control.

Encourage natural predators of pest invertebrate species, such as hedgehogs, frogs and toads, by installing Hedgehog Highways, wild areas and wildlife ponds.



Machinery

Hedgehogs have no flight reflex and nest year round, making them vulnerable to machine injury.

The solution

The timing and method of habitat clearance has an impact on hedgehogs, but will need to be balanced with other biodiversity needs.

Bramble disturbance is least hazardous in autumn to avoid the bird breeding season, the bulk of hedgehog breeding, and hibernation. Hedgehogs are generally absent from long grass in winter, making this the least hazardous time for cutting, but this isn't necessarily the best time to cut wildlife meadows. We recommend rotational cutting so that there's always an area left unstrimmed for insects to feed on and hedgehogs to nest in.

A high-cut, low-cut method allows nest checks in-between, and increasing the blade height of mowers will minimise risks. Ensure all machine users are trained to be hedgehog aware. BHPS offer free waterproof stickers for machines to remind operatives to check for hedgehogs.



Drowning

Ponds and lakes are excellent habitat and provide an important water source for hedgehogs in times of drought. Hedgehogs are good swimmers, but even small ponds are a hazard if they can't climb back out.

The solution

Ensure there are entry and exit points to water bodies by designing wildlife friendly ponds with shallow beaches. Reduce hazards to existing water bodies by creating ramps out of bricks, logs or sand bags. Ramps should ideally be 20cm wide and no steeper than 30 degrees.



Entanglement

Litter, wire fencing and loose or fine vegetable netting poses a risk to hedgehogs. Cricket nets and football goals are also common places for entrapment.

The solution

Information boards and adequate bins around sites will encourage responsible litter disposal. Tie up sports netting when not in use and keep fruit netting tight. Replace fine diameter thread with thicker netting or use a rigid structure instead.



Bonfires and compost heaps

Bonfires and compost heaps are attractive nesting sites for wildlife but can be particularly hazardous to hedgehogs who lack a flight mechanism.

The solution

Relocate the bonfire material from its storage location to a new pile on the day of burning, so it's thoroughly checked before being lit. Where this isn't possible, fence the pile using steep plastic sheeting. Reptile fencing used by a local ecological consultant is suitable for this purpose.



Consider leaving an open compost heap for wildlife and maintaining an active compost heap in an enclosed container, inaccessible to hedgehogs.

Disease, injury and ailments

Thousands of hedgehogs are admitted to vets and rescue centres across the country every year. Hedgehogs are well known for their association with ticks and fleas, but can also carry and suffer from diseases such as salmonella, lungworm and ringworm. The population-level impact of these diseases on wild hedgehogs is still being researched.

Hedgehog fleas are species-specific, and the presence of ticks is normal unless they're carrying a particularly high burden, which can be indicative of ill-health. Hedgehogs seen out in the day exhibiting non-purposeful behaviour may require further assistance, but it's always best to obtain advice before removing a hedgehog from the wild.

The solution

Contact BHPS on 01584 890 801 for further information and advice about injured or ill hedgehogs.

Reports of hedgehogs that are thought to have died from disease can be submitted to Garden Wildlife Health - a collaborative project working to monitor the health and identify disease threats to British wildlife based at ZSL: www.gardenwildlifehealth.org. They can also conduct autopsies on preserved specimens, but please contact them before sending any samples.



Predation

Foxes and dogs

Foxes and dogs can cause hedgehog mortality, but there's no indication that they impact hedgehog populations as a whole. Small populations may be more vulnerable.



Badgers

Badgers are the main natural predator of hedgehogs and also compete for similar prey. It's thought that the two species can coexist as they have for thousands of years, so long as there's enough feeding and nesting habitat for them both.

The solution

A good network of hedging, scrub and bramble provides nesting habitat for hedgehogs and cover from predators. Fence off prime natural nesting sites in public areas to reduce disturbance from dogs, ensuring the fencing is hedgehog permeable. Whilst not advised as a replacement for natural habitat, purpose-built hedgehog houses can provide additional protection from predators. Tunnels and small entrance holes (13x13cm) are best for these. See our hedgehog housing leaflet for tips www.hedgehogstreet.org/hedgehog-homes

Legislation

Hedgehogs are listed as a UK 'Priority Species' under S41 of the NERC Act (2006). They also have limited protection under Schedule 6 of the Wildlife and Countryside Act (1981) as amended, which means they cannot be caught or trapped without a licence. The Wild Mammals (Protection) Act (1996) prohibits cruel activities and mistreating of hedgehogs.

No legislation currently addresses the causes of decline in hedgehog populations.



How to detect hedgehogs

Check the Big Hedgehog Map for records local to you: www.bighedgehogmap.org, or add your own sighting. If hedgehogs have been recorded locally and suitable habitat is present, it's likely that the area will be used in some form due to their wide-ranging behaviour.

If you'd like to know whether hedgehogs are using your green-space, footprint tunnels or trail cameras are the easiest and most cost effective way of monitoring.

Footprint tunnels are cheap and easy to construct, and can be placed along linear features such as hedgerows, fences and walls. Pieces of A4 paper are attached to the inside of the tunnel, alongside two strips of non-toxic ink and a handful of meaty flavoured cat, dog or hedgehog food. The tunnels can be kept in place for up to five nights, with paper and bait being replenished daily.

If you manage to detect hedgehogs then a trail camera is a brilliant way of observing behaviour and sharing your successes with the local community. Place these around 20cm from the ground on a wooden stake, or lock them discretely to fencing or trees.

For more advice about conducting a hedgehog survey, please contact hedgehogs@ptes.org.

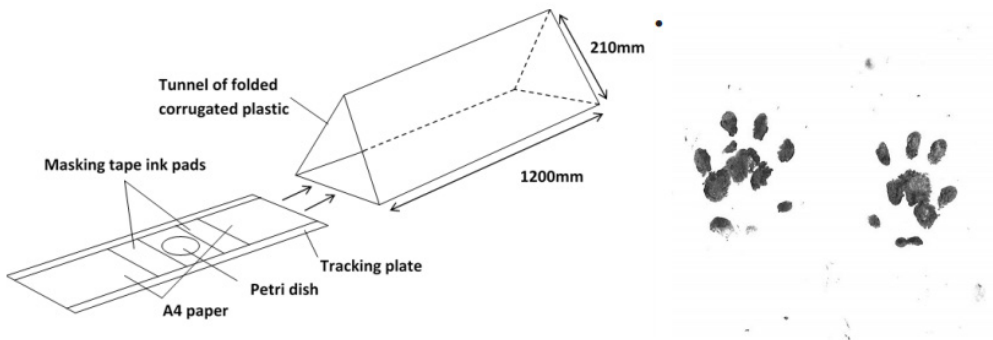

This handbook accompanies the more extensive *Hedgehog Ecology & Management Course for Practitioners*, run by PTES and BHPS. This is a one-day course aimed at land managers and consultants to inform green-space management.

For more information and to locate your nearest course leader, visit www.ptes.org/hedgehogtraining

HEDGEHOG STREET



CITY OF WILDLIFE

Hedgehog Street is a joint project run by People's Trust for Endangered Species and the British Hedgehog Preservation Society.

hedgehogs@ptes.org

www.hedgehogstreet.org

We'd like to thank Ali North at Suffolk Wildlife Trust for her contribution to this guidance booklet.

people's
trust for
endangered
species

020 7498 4533
enquiries@ptes.org
www.ptes.org
registered charity no. 274206



01584 890 801
info@britishhedgehogs.org.uk
www.britishhedgehogs.org.uk
registered charity no. 1164542